

BZA

WITH KEYWAY MOUNTING

1,900 – 480,000 Nm

**NEW**

PROPERTIES

MATERIAL

► Coupling from high strength steel

DESIGN

Hub with keyway connection or cylindrical bore for shrink disc.
Optional set screw for keyway DIN 916.
Customer specified intermediate length also available.

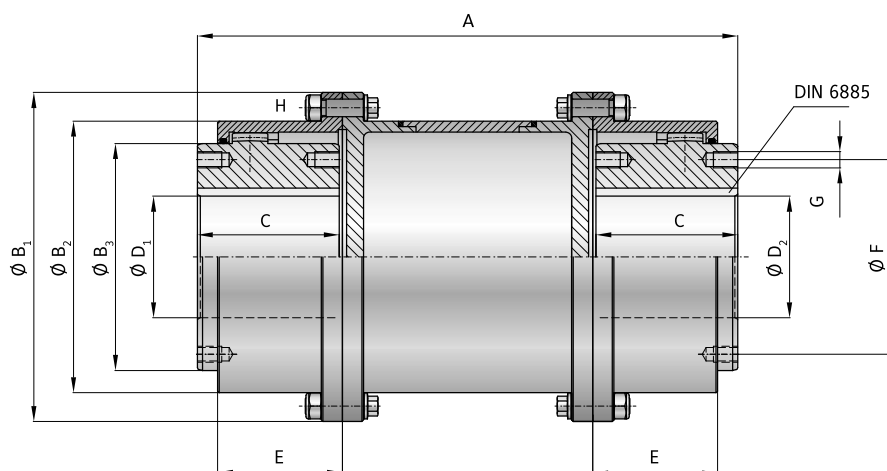

MODEL BZA | SIZE 10 – 2000

SIZE		10	25	50	100	150	200	300	450	600	800	1500	2000
Rated torque (kNm)	T_{KN}	1.9	2.9	5.7	9	14.5	22	34	45	70	85	150	200
Max. torque (kNm)	T_{Kmax}	4.2	6.8	14	21.5	35	54	83	110	170	205	360	480
Installed length (mm)	A	89	103	127	157	185	216	246	278	308	358	388	450
Outside diameter (mm)	B_1	111	142	168	200	225	265	300	330	370	406	438	505
Flange diameter (mm)	B_2	82.5	104.6	130.5	158.4	183.4	211.5	245.5	275.5	307	335	367	423
Hub diameter (mm)	B_3	68	86	105	132	151	179	209.5	234	255	280	306	356
Hub fit length	C	43	50	62	76	90	105	120	135	150	175	190	220
Max bore diameter H7 with 1 / 2 keyways*	$D_{1/2}$	48 / 52	62 / 62	72 / 78	90 / 98	105 / 112	122 / 132	144 / 156	160 / 174	175 / 190	192 / 210	210 / 233	245 / 280
Bore diameters from ϕ to ϕ H7 with interference fit	$D_{1/2}$	12-52	18-62	30-78	32-98	42-112	45-132	50-156	60-174	70-190	90-210	110-233	120-280
Hub length (mm)	E	39	46	59	78.5	92.5	108	123	139	154	179	194	225
Hole circle diameter (mm)	F	61	73	91	115	132	154	180	204	220	240	268	316
Thread size	G	M5	M6	M8	M10	M12	M12	M16	M16	M20	M20	M24	M24
Bolt	H	M8	M10	M10	M12	M12	M16	M16	M16	M18	M22	M22	M24
Tightening torque (Nm)		18	36	36	65	65	150	150	150	220	400	400	520
Axial misalignment (mm)	S	1.5	1.5	1.5	2.5	2.5	3	4	4	4	4	4	5
Angular misalignment (Degree)		2×0.35	2×0.35	2×0.35	2×0.35	2×0.35	2×0.35	2×0.35	2×0.35	2×0.35	2×0.35	2×0.35	2×0.35

* Larger maximum bore possible with 2 keyways, due to increased stress distribution versus wall thickness.

ORDERING EXAMPLE	BZA	50	1200	60	50	XX
Model	●					
Size		●				
Overall length mm			●			
Bore ϕ D1 H7				●		
Bore ϕ D2 H7					●	

Special designation only (e.g. special bore tolerance).

For custom features place an XX at the end of the part number and describe the special requirements (e.g. BZA / 50 / 1200 / 60 / 50 / XX)

BZA

WITH KEYWAY MOUNTING

290,000 – 2,080,000 Nm

**NEW**

PROPERTIES

MATERIAL

► Coupling from high strength steel

DESIGN

Hub with keyway connection or cylindrical bore for shrink disc. Optional set screw for keyway DIN 916. Customer specified intermediate length also available.

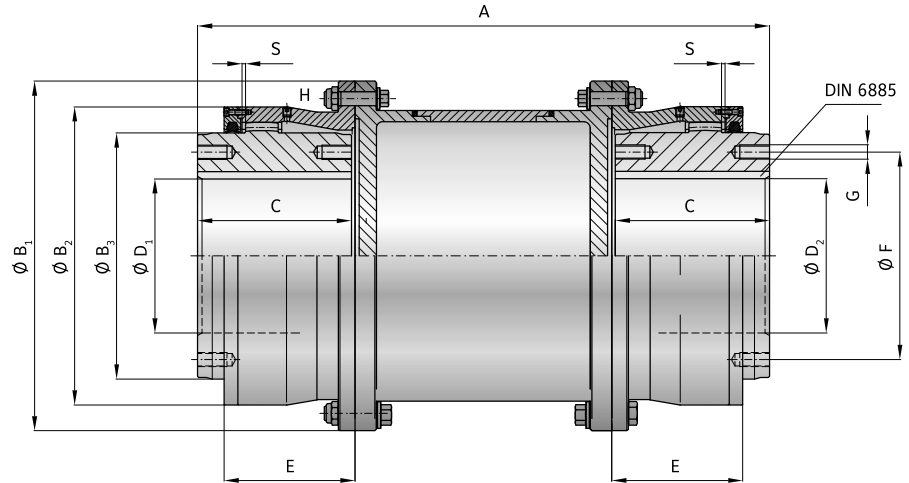

MODEL BZA | SIZE 3000 - 10000

SIZE			3000	4000	5000	7000	8000	10000
Rated torque	(kNm)	T_{KN}	290	402	518	693	882	1040
Max. torque	(kNm)	T_{Kmax}	580	804	1036	1386	1764	2080
Installed length	(mm)	A	532	592	652	712	772	820
Outside diameter	(mm)	B_1	590	639	702	769	834	894
Flange diameter	(mm)	B_2	503	553	597	657	722	763
Hub diameter	(mm)	B_3	415	464	490	545	620	660
Hub fit length	(mm)	C	260	290	320	350	380	400
Bore diameter H7	(mm)	$D_{1/2}$	160-325	180-370	200-400	200-430	230-475	250-510
Bore diameters from ϕ to ϕ H7 with interference fit	(mm)	$D_{1/2}$	160-325	180-370	200-400	200-430	230-475	250-510
Hub length	(mm)	E	221	245.5	262	280	292	315
Hole circle diameter	(mm)	F	350	400	430	490	560	580
Thread		G	M24	M24	M30	M30	M24	M36
Bolt		H	M24	M24	M30	M30	M30	M36
Tightening torque	(Nm)		670	670	1250	1250	1250	2170
Axial misalignment	(mm)	S	6	6	6	6	6	10
Angular misalignment	(Degree)		2×0.35	2×0.35	2×0.35	2×0.35	2×0.35	2×0.35

CROWNED GEAR
COUPLINGS BZ

ORDERING EXAMPLE	BZA	3000	1200	160	280	XX
Model	●					Special designation only (e.g. special bore tolerance).
Size		●				
Overall length mm			●			
Bore ϕ D1 H7				●		
Bore ϕ D2 H7					●	

For custom features place an XX at the end of the part number and describe the special requirements (e.g. BZA / 3000 / 1200 / 160 / 280 / XX)