

# 7PROGLCD

## HANDHELD PROGRAMMER



**- USER'S GUIDE -**



## 7PROGLCD HANDHELD PROGRAMMER

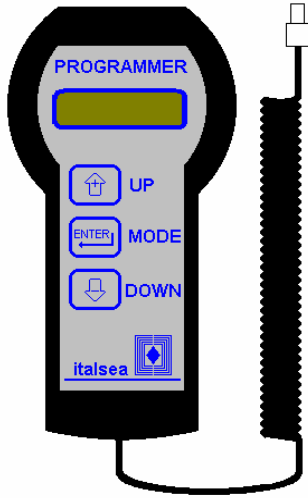

fig.1

**LCD 16X2:**

Displays parameters, alarms and measures (description and value).

**UP Key:**

Rolls up parameters and increases values.

**MODE Key:**

Confirms a selection and the change of value.

**DOWN Key:**

Rolls down parameters and decreases values.

At power-on, handheld programmer displays the “Tester Mode” page. In this pages , you’ll find the motor current and voltage, speed reference input, internal aluminum heat-sink temperature, battery voltage, hour-meter and software release.

To start the programming function push the button “MODE” .

Will appear the first parameter; pushing the “UP” button the number of the parameter will be increased and with the “DOWN” button the number will be decreased. When a parameter is selected , push the button “MODE” to enter in the change menu, change the value with the buttons “UP” and “DOWN”, then confirm the parameter with the button “MODE”. To return to the TESTER menu push together the buttons “MODE “and “UP”, or wait few seconds.

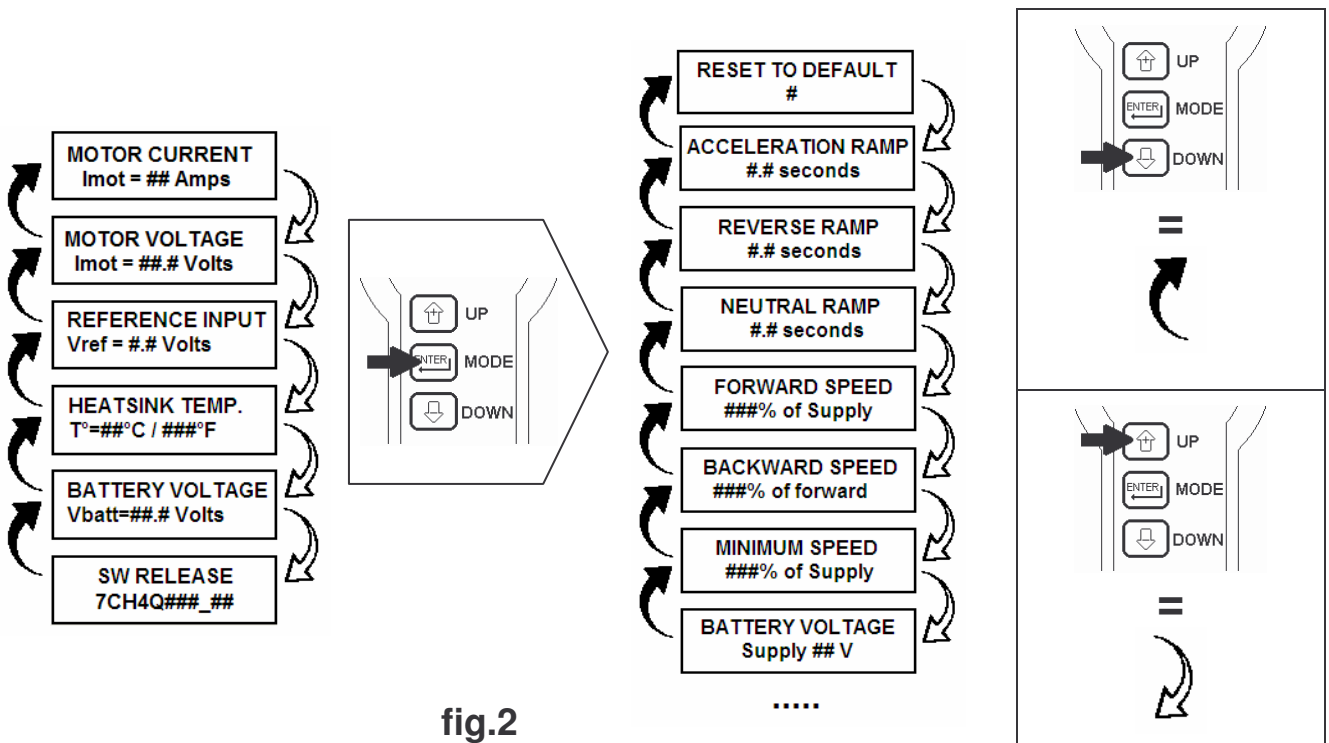

fig.2