



UDMmc

Functional Safety Manual

July 2020

Document Revision: 1.10

UDMmc

ReleaseDate: April 2020

COPYRIGHT

© ACS Motion Control Ltd.2020.All rights reserved.

Changes are periodically made to the information in this document. Changes are published as release notes and later incorporated into revisions of this document.

No part of this document may be reproduced in any form without prior written permission from ACS Motion Control.

TRADEMARKS

ACS Motion Control, SPiiPlus,PEG, MARK, ServoBoost, NetworkBoost, and NanoPWM are trademarks of ACS Motion Control Ltd.

Windows and Visua lBasic are trademarks of Microsoft Corporation.

EtherCAT is a registered trademark and patented technology, licensed by Beckhoff Automation

GmbH,Germany. Any other companies and product names mentioned herein may be the trademarks of their respective owners.

www.acsmotioncontrol.com

support@acsmotioncontrol.com

sales@acsmotioncontrol.com

NOTICE

The information in this document is deemed to be correct at the time of publishing. ACS Motion Control reserves the right to change specifications without notice. ACS Motion Control is not responsible for incidental, consequential, or special damages of any kind in connection with using this document.

Revision History

Date	Revision	Description
April 2020	1.00	First release





Conventions Used in this Guide

Text Formats

Format	Description
Bold	Names of GUI objects or commands.
BOLD+ UPPERCASE	ACSPL+ variables and commands

Monospace + grey background	Code example.
<i>Italic</i>	Names of other documents.
Blue	Web pages, and e-mail addresses.
[]	In GUIs indicates optional item(s)
	In GUIs indicates either/or items

Flagged Text

	Note - includes additional information or programming tips.
	Caution - describes a condition that may result in damage to equipment.
	Warning - describes a condition that may result in serious bodily injury or death.
	Model - highlights a specification, procedure, condition, or statement that depends on the product model.
	Advanced - indicates a topic for advanced users.

Related Documents

Documents listed in the following table provide additional information related to this document.

The most updated version of the documents can be downloaded by authorized users from www.acsmotioncontrol.com/downloads.

Online versions for all ACS software manuals are available to authorized users at [ACS Motion Control Knowledge Center](#).

Document	Description
----------	-------------

UDMmc Installation Guide

Provides installation information.

Table of Contents

1. Introduction.....	7
1.1 Overview.....	7
1.3 STO block diagram.....	8
1.4 Certification.....	8
1.5 Operator responsibility.....	9
1.5.1 Safety considerations.....	9
2. Certified products list.....	10
2.1 List of certified products.....	11
2.2 UDMmc order part number.....	11
3. Reliability data (PFD and PFH).....	12
4. STO specification.....	14
4.1 Environmental specification.....	14
5. Installation requirements.....	15
5.1 STO connector.....	15
5.2 STO connector pinout.....	15
5.3 Wiring and cables.....	16
5.4 Mating connector.....	16
5.5 Power supplies.....	16
5.6 Typical system configuration.....	16
6. Diagnostic and Functionality.....	17
6.1 STO diagnostic.....	17
6.2 Recovery from a STO event.....	18
7. Verify operation.....	18
7.1 Maintenance and diagnosis.....	18
7.1.1 Automatic test.....	18
7. Verify operation.....	20
7.1.2 Manual test.....	21

Table of Figures

Figure 1: STO block diagram.....	8
Figure 2: UDMmc Label.....	11
Figure 3: STO J2 Connector. Label of right side of UDMmc cover.....	15
Figure 4: STO J2 Connector. Label of top side of STO UDMmc cover.....	15
Figure 5: Typical System Configuration.....	17
Figure 6: Sample warning message.....	Error! Bookmark not defined.
Figure 7: J2 signals and its LEDs.....	19
Figure 8: STO J2 Connector and its LEDs.....	20
Figure 9: J2 signals and its LEDs.....	21

List of Tables

<i>Table 1: UDMmc ordering options</i>	11
<i>Table 2: Functional safety data</i>	12
<i>Table 3: STO input specification</i>	14
<i>Table 4: Environmental specification</i>	14
<i>Table 5: STO Connector Description</i>	16

1. Introduction

1.1 Overview

Functional safety in the UDMmc is implemented by the STO (Safe Torque Off) function. The STO prevents:

- Unexpected motor movement
- Rotational field within the motor
- The motor from generating torque on the shaft

This manual describes the use of the STO function in the UDMmc.

The STO is applicable only to drives that are certified for functional safety, see Certified products list.

This manual includes critical information, including expected behavior of the motion systems when using the STO, limitations, and the requirements for three-month testing by the user.

1.2 What is STO?

The Safe Torque Off (STO) functionality disables the drive's output MOSFET's according to IEC 618005-2, by disconnecting power and input signals from the gate drive optocouplers. This results in preventing the drive's output power devices from switching in the necessary way to generate AC power to the motor. When STO is enabled while the motor is in motion, the motor shaft and its mechanical elements coast until brought to a stop. When the STO is enabled, the drive cannot generate torque energy. The safety function "Safe torque off" (STO) can be used to realize an "Emergency Stop" according to EN60204 Stop 0 while the power is still supplied to the frequency inverter.



STO can be used in applications where the motor is expected to reach a standstill within a sufficiently short time based on the load and the friction and when coasting down of the motor will not have any impact on safety.



Systems with a suspended load must have an additional mechanical safety block like a motor brake. The drive cannot hold the load when STO is engaged. When designing a machine, consider the timing and distance for a coasting to stop. Serious injury could result if the load is not properly held.



The maximum service life of the STO equipped drive is 20 years. After 20 years the STO equipped drive must be decommissioned.

1.3 STO block diagram

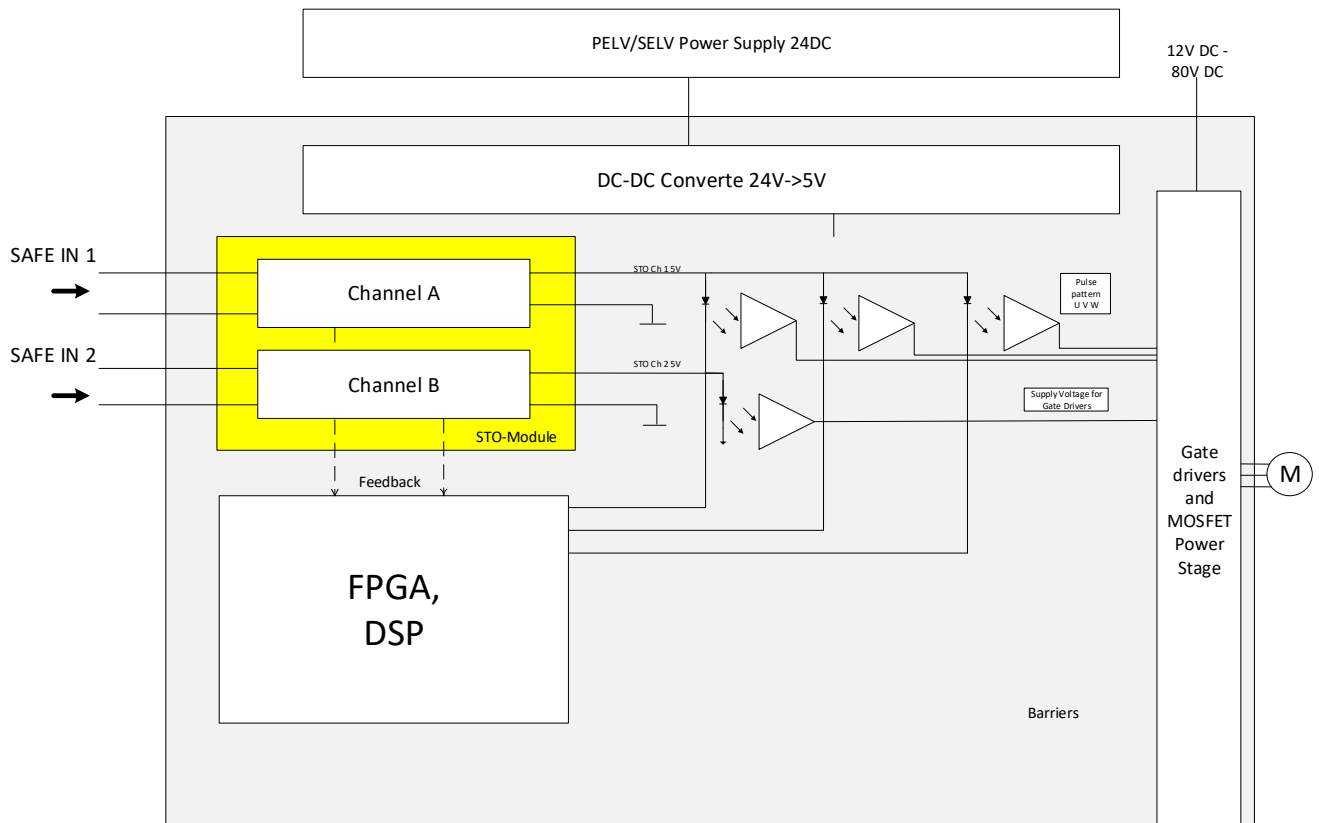

Figure 1: STO block diagram

1.4 Certification

The UDMmc Safe Torque Off module is certified for use in safety applications up to and including SIL-3 according to:

- EN/IEC 61800-5-2 Ed. 2 (second environment)
- EN/ IEC 61800-5-1
- IEC 61508
- IEC 62061

Performance Level PLe and Category 3 according to:

- EN/ISO 13849-1/-2

1.5 Operator responsibility

1.5.1 Safety considerations

- When applying Functional Safety, restrict access to qualified, authorized personnel who are trained and experienced.
- The operator must perform a periodic test of the STO function every three months in order to make sure the STO is working properly. See [Verify operation](#) for test details.



In the event of the failure of two output MOSFET's in the drive, when STO is activated (removing the power from the optocouplers) , the drive can provide energy for up to 180° of rotation in a 2-pole motor before torque production in the motor ceases. However, the probability of such a failure is rare and therefore considered negligible.



Failure to maintain the specified environmental standards can result in a failure of the safety function.



The STO does not eliminate dangerous voltages at the drive output. Input power to the drive (drive supply) must be removed before performing any electrical work on the drive or machine.

2. Certified products list



DECLARATION OF CONFORMITY

ACS Motion Control Ltd.

5 Ha'Tnufa st. Yokneam Industrial Park, Israel, 2066717

Israel, Tel: +972 4 654 6440 Fax: +972 4 654 6443

ACS Motion Control Ltd., declare on our sole responsibility that the following products:

UDMmc

1. Adhere to the following reference standards including Machinery Directive 2006/42/EC Annex IX and VIII. Applied harmonized standards:

- a. IEC 61800-5-2:2016
- b. IEC 61800-5-1:2016
- c. IEC 61800-3: 2017
- d. EN ISO 13849-1:2015
- e. EN ISO 13849-2:2012
- f. IEC 62061:2015
- g. IEC 60204-1:2016 (in extracts)

ACS Motion Control Ltd. Officer:

Signature:

Printed Name: Dror Marom, CEO

Date: 19/04/20

2.1 List of certified products

All the below products have been approved by The TÜV Rhineland for the Safe Torque Off option, for use in safety-related applications where the torque off state is considered to be the safe state.

The below products were certified:

- UDMmc, see UDMmc order part number for more details.

2.2 UDMmc order part number

The order part number (P/N) contains several characters (see example in Figure 2) that each specify a configuration characteristic ordered for the UDMmc module, as described in Table 1.

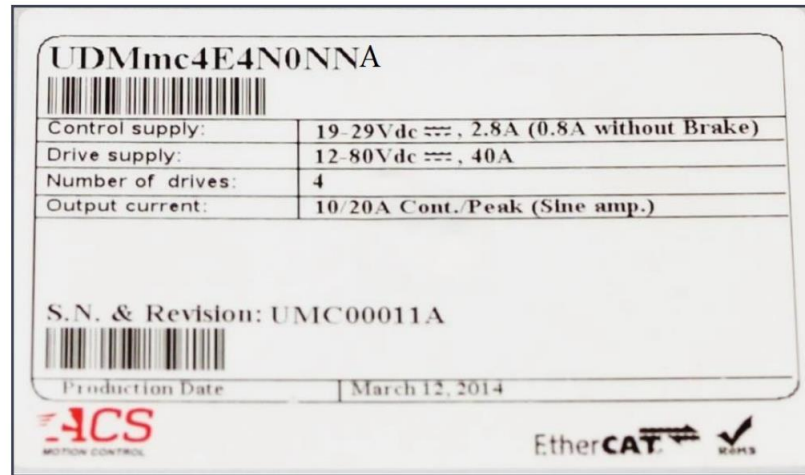

Figure 2: UDMmc Label

Table 1: UDMmc ordering options

Ordering Options	Field	Example User Selection	Available Ordering Option Values
Number of axes	1	4	2,4
Continuous Current (Peak is double)	2	E	2x5A (A), 2x10A (B), 2x20A (C), 4x2.5A (J), 4x5A (D), 4x10A (E), 4x20A (F) 2x5A & 2x10A (G) 2x5A & 2x20A (H) 2x10A & 2x20A (I)
Total number of digital incremental encoders	3	4	2, 4 For 4-axis select 4
Absolute encoders type	4	N	All-(U) None (N) EnDat 2.1(Digital)/2.2(E) Smart Abs(S) Panasonic(P) BiSS-A/B/C(B)

Ordering Options	Field	Example User Selection	Available Ordering Option Values
			SSI(I)
Number of absolute encoder interface	5	0	0, 1, 2, 3, 4
STO	6	N	Yes (Y), No (N)
I/O configuration	7	N	(N): Inputs & limits: 24V/SOURCE (PNP), outputs: 24V/SOURCE (PNP). (S): Inputs & limits: 24V/SINK (NPN), Outputs: 24V/SOURCE (PNP). (A): Inputs & limits: 5V/ SOURCE (PNP), Outputs: 24V/SOURCE (PNP). (B): Inputs & limits: 5V/SINK (NPN), Outputs: 24V/SOURCE (PNP).
5V Feedback supply	8	A	(A) Internal (B) External

3. Reliability data (PFD and PFH)

Safety-related systems can be classified as operating in either a Low Demand mode or in a High Demand/Continuous mode.

PFD and PFH calculations are based on the equations from Part 6 of IEC 61508.

Table 2 shows the functional safety data of the UDMmc.

Table 2: Functional safety data

	STO
PFD	2,27E-6
PFH	1,24E-11
PL	E

SIL	3
Category	3
MTTF _D	390521y

4. STO specification

Table 3 describes the STO input specification.

Table 3: STO input specification

Name	Description	Value	Note
STO power supply	24V supply (nominal)	24Vdc	
	Power supply type	SELV/PELV	
Input current	@18Vdc	70mA	
	@33Vdc	18mA	
Input ON voltage (minmax)	Input ON voltage (min-max)	18-33Vdc	
Input OFF voltage (Max)	Input OFF voltage (Max)	<5V	
Input OFF current (max) @5V	Input OFF current (max) @5V	0.15mA	
Maximum reaction time (ms)	Time from STO activation until the power is removed from optocouplers	460mS	
Maximum duration of OSSD pulse	Duration of pulse that will active the STO function	<1mS, with period of >200ms	

4.1 Environmental specification

Table 4: Environmental specification

Category	Specification	Note
Operational temperature	0-40°C	
Storage temperature	0-70°C	

Humidity	10-90%	
Altitude	Up to 2000m	
Pollution degree	2	
EMC	IEC 61800-3 IEC 61800-5-2 Ed. 2 (second environment)	



Failure to maintain the specified ambient temperature can result in a failure of the safety function.

5. Installation requirements

5.1 Environmental requirements

The drive shall be mounted into a housing or environment that provided at least IP54 protection.

1. Protected from limited dust ingress.
2. Protected from water spray from any direction.

5.2 STO connector

The STO is connected to J2 in UDMmc.

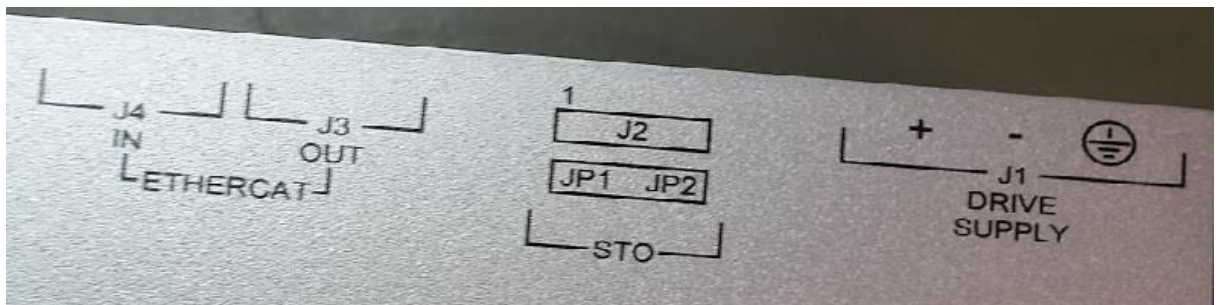

Figure 3: STO J2 Connector. Label of right side of UDMmc cover



Figure 4: STO J2 Connector. Label of top side of STO UDMmc cover

5.3 STO connector pinout

Table 5 describes the J2 STO connector.

Table 5: STO Connector Description

	Name	Description
1	ST01	STO input 1, 24V return input
2	ST01	STO input 1, +24V input
3	NC	not connected
4	ST02	STO input 2, +24V input
5	ST02	STO input 2, 24V return input

5.4 Wiring and cables

It is recommended to use 22-24 AWG copper wire with an insulation rating of 600V or higher.

The STO cable must be shielded and isolated from any sources of environmental stress.

The measures of EN13849-2 D.7 for the connector wiring is required.

5.5 Mating connector

The STO (J2) mating connector is JST 5 PIN2mm female PAP-05V-S. The pin type for this connector is: SPHD-001T-P0.5

5.6 Power supplies

The external power supply that feeds the STO input is to be low voltage 24Vdc±10% power supply that complies with EN60950 (SELV) or EN50178 (PELV).

5.7 Typical system configuration

A typical system configuration includes:

- ACS drive (UDMmc with STO module (SB-16530-200/LF))
- Emergency stop or another switch
- SELV/PELV power supply (24Vdc)

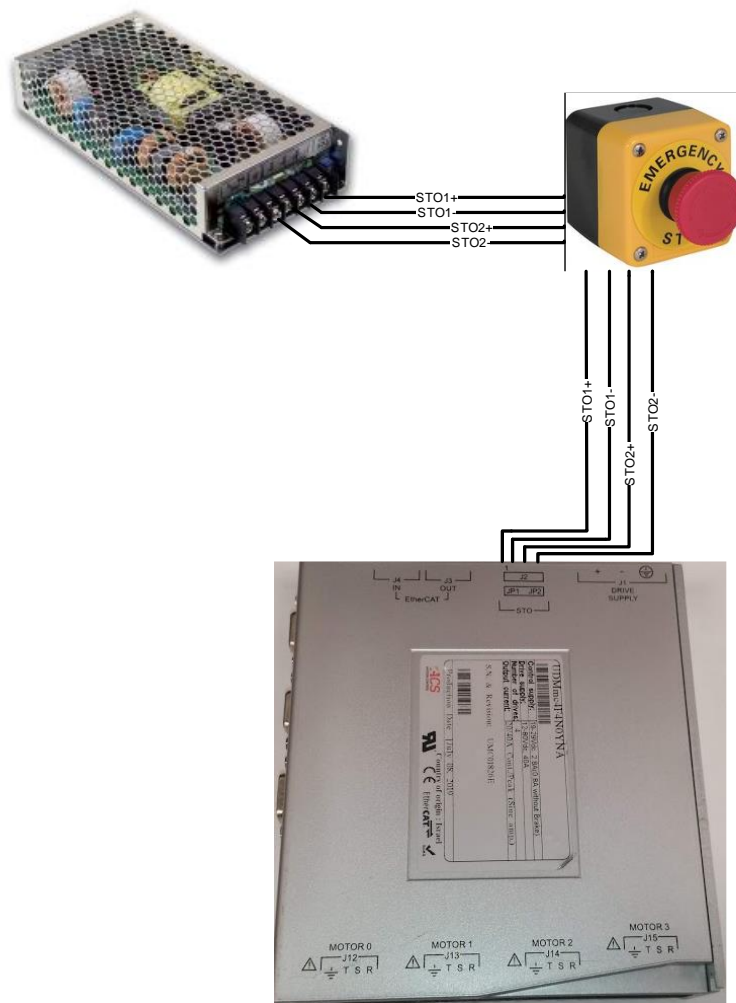

Figure 5: Typical System Configuration

6. Diagnostic and Functionality

6.1 STO diagnostic

When STO is activated, i.e. power is removed from one of the STO safe channels input (24Vdc), it disables the drive's output MOSFETS's by removing the power from the gate drive optocouplers. The ST01 and ST02 LEDs are OFF. The controller monitors the STO signals (in the ACS SPiiPlus MMI Application Studio software interface) as shown in Figure 6.

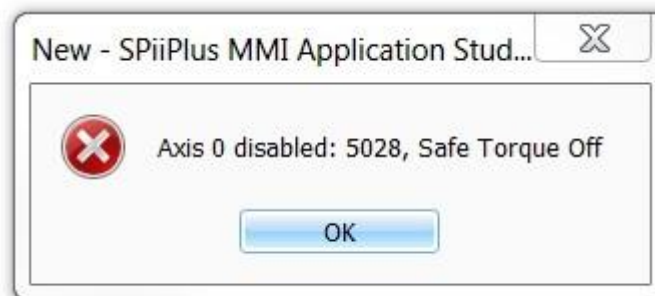

Figure 6: Sample warning message

STO 1 is activated (no voltage applied to 24_STO1 input)

STO2 is deactivated (24V applied to 24_STO2 input)

6.2 Recovery from a STO event

After activation of STO (power removed from optocouplers), the system can be restarted by resetting the STO inputs (both channels receive power of 24Vdc) and the drive is activated using an additional ENABLE_S command. The ENABLE_S command is not safety related but must be integrated in a way so that a stuck-at fault cannot rerun the drive automatically. In some applications, an automatic rerun is required, this case requires an additional signal or command initiated by the Control system.

7. Verify operation

7.1 Maintenance and diagnosis

It is the user's responsibility to perform periodic tests to ensure that the STO circuits are functioning.

The two options to perform aperiodic tests are Automatic test or Manual test.

The periodic test should be performed every three months.

7.1.1 Automatic test

When the STO is connected with a Safety PLC controller, the Safety-PLC controller is responsible for testing in sufficient cycle time. In this case, a feedback signal concerning the motion state of the motor must be checked.

The PLC must test each input separately in the following sequence:

1. *PLC controller activates both channels of STO, i.e. disconnects the 24V of both STO inputs on J2.*
2. *User D LJK verify that both LEDs, STO1 and STO2 are off.*
3. *Motion controller sends command to the motor to start motion.*
4. *PLC controller reads the motor feedback and verifies no motion.*
5. *PLC controller applies 24V between pin 1 and 2 of J2 (STO channel 1 deactivated).*
6. *User has to verify that STO1 LED is on and STO2 LED is off.*
7. *Motion controller sends command to the drive to start motion.*
8. *PLC controller reads the motor feedback and verifies no motion.*
9. *PLC disconnects the 24V from pin 1 and 3 of J2.*
10. *PLC connects 24V between pins 4 and 5 of J2 (STO channel 2 deactivated).*
11. *User has to verify that STO2 LED is on and STO1 LED is off.*
12. *Motion control sends command to the drive to start motion.*
13. *PLC controller reads the motor feedback and verify no motion.*
14. *PLC reconnects both STO channels (deactivate the both STO channels).*

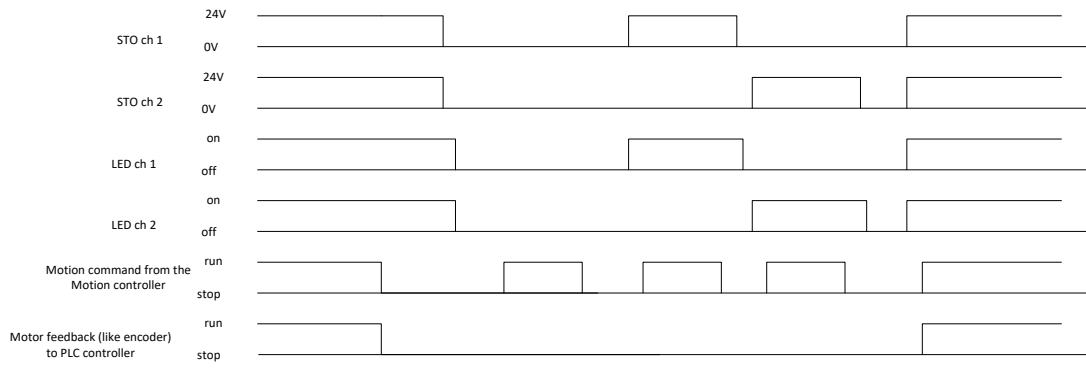

Figure 7: J2 signals and its LEDs

STO ch 1: STO input channel 1

STO ch 2: STO input channel 2

7. Verify operation

LED ch 1: Signal LED of channel 1 status see Figure 8(STO1)

LED ch 2: Signal LED of channel 2 status see Figure 8 (STO2)

Motion command from the motion controller: the motion controller send command to the drive to start motion.

Motor feedback (like encoder) to safety PLC: motor feedback (like encoder or others) from motor to the PLC controller.



Figure 8: STO J2 Connector and its LEDs

7.1.2 Manual test

The user tests the STO safe inputs by activating the STO function channel wise cyclically and checks that the LED's are off (STO1 and STO2, as in the picture above) depending by the activated channel.

The user is to test each input separately in the following sequence:

1. Activate both channels of STO, i.e. to disconnect the 24V of both STO inputs on J2.
2. Make sure both LEDs, STO1 and STO2 are off.
3. Deactivate STO channel 1 only (apply 24V between pin 1 and 2 of J2).
4. Make sure STO1 LED is on and STO2 LED is off.
5. Disconnect the 24V from pin 1 and 3 of J2.
6. Connect 24V between pins 4 and 5 of J2.
7. Make sure STO2 LED is on and STO1 LED is off.
8. Reconnect both STO channels (deactivate the both STO channels).
9. Make sure both LEDs, STO1 and STO2, are on.

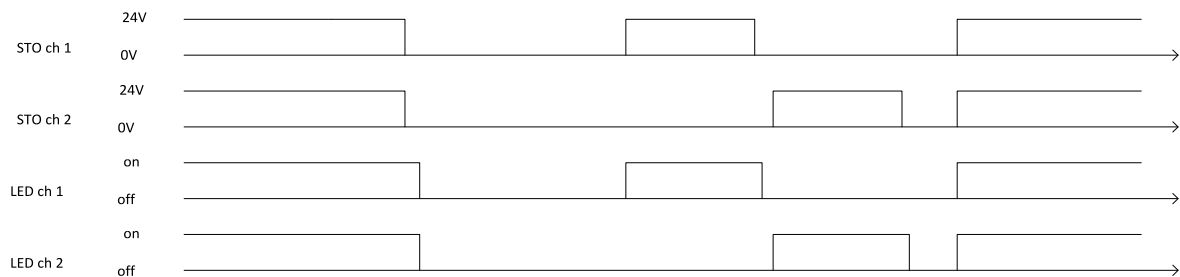

Figure 9: J2 signals and its LEDs

*5 HaTnufa Street,
Yokneam Industrial Park, Israel, 2066717
Tel: (+972)(4)6546440 Fax: (+972)(4)6546443*

Contact us: sales@acsmotioncontrol.com | www.acsmotioncontrol.com